



Operation & Maintenance Manual

FX-MVAC SERIES



READ AND SAVE THESE INSTRUCTIONS

Visit our Website for more information on this product

www.fumextractors.com

11088 Gravois Industrial Ct. Saint Louis, MO 63128
Tel: 1.866.651.9762 | info@fumextractors.com

Table of Contents

| | |
|---|------------|
| SECTION 1 – SAFETY PRECAUTIONS OF FUME & DUST EXTRACTION/COLLECTION | 3 |
| 1.1 Symbols | 3 |
| 1.2 User Responsibility | 3 |
| 1.3 Fume Extraction Hazards | 3 |
| 1.4 Dust Collection Hazards | 3 |
| 1.5 Safety Stickers | 4 |
| SECTION 2 – SPECIFICATIONS | 4 |
| 2.1 Diagram & Descriptions..... | 4 |
| 2.2 Product Specifications..... | 4 |
| 2.3 Filter Specifications..... | 4 |
| SECTION 3 – PRE - INSTALLATION | 5 |
| 3.1 To Setup or Install Safely | 5 |
| 3.2 Un-Packaging | 5 |
| 3.3 Selecting a Location..... | 5 |
| 3.4 Standard View: Side & Back..... | 5 |
| 3.5 Standard View: Top & Isometric..... | 5 |
| SECTION 4 – OPERATION | 6 |
| 4.1 To Operate Safely | 6 |
| 4.2 Controls | 6 |
| 4.3 Pre-Use Checklist | 6 |
| 4.4 Principles of Operation | 6 |
| 4.5 Failure Event | 7 |
| SECTION 5 – MAINTENANCE & TROUBLESHOOTING | 7 |
| 5.1 To Maintain this Product Safely | 7 |
| 5.2 Tools Required | 8 |
| 5.3 Routine Maintenance Schedule..... | 8 |
| 5.4 Servicing Filter | 8 |
| 5.5 To Troubleshooting Procedure..... | 9 |
| APPENDIX 1 - ELECTRICAL DIAGRAM MANUAL..... | 10 |
| APPENDIX 2 – MAINTENANCE RECORD | 11 |
| APPENDIX 3 - REPLACEMENT PARTS..... | 12 |
| APPENDIX 4 - SAMPLE SAFETY STICKERS..... | 13 |
| NOTES..... | 14,15 |
| Limited Equipment Warranty | Back Cover |
| Freight Claims | Back Cover |
| Return Material Policy | Back Cover |

SECTION 1 - SAFETY PRECAUTIONS OF FUME & DUST EXTRACTION/COLLECTION



READ
BEFORE
USE

This manual contains specific cautionary statements related to worker safety. To protect yourself and others, read this manual thoroughly and follow as directed before use. Not all hazards of fume & dust control are listed in this manual, and no hazards related to welding, cutting, grinding, painting, deburring or other applications are listed. Consult a qualified safety professional.



DO
NOT
USE

Do not use this equipment:

- To extract combustible dusts, liquid vapors, aggressive fumes such as acids.
- To extract smoke or fumes above 180°F / 82°C.
- If the power cord has been damaged or ground (third prong) removed.
- Without a filter.

1.1 Symbols

This manual uses several symbols to highlight specific hazards. Be familiar with these symbols and when you see them in this manual, read adjoining warning text to avoid the hazard.



WARNING!
DANGER!



ELECTRIC
SHOCK



MOVING
PARTS



HOT
PARTS

1.2 Users Responsibility

- Improper use can be hazardous. The unit weighs 48 lbs, care should be taken when transporting.
- All users must carefully read and understand this instruction manual prior to use
- For maintenance of any and all components, power switch must be off and the power source disconnected
- It is your responsibility to follow all applicable ANSI, OSHA, UL, CSA, National & Local Fire Codes, and other regulatory guidelines covering the safe use of equipment that extracts fumes, collects dusts, and exhausts filtered air either indoors or outdoors.
- Before use, inspect the unit for damage and verify it is working properly.
- Only qualified persons should install, operate, maintain, or repair this unit.
- Do not modify or repair the unit with parts or accessories not supplied by the manufacturer.
- Consult filter manufacturer's instructions for filter use and reuse, including instructions for cleaning.

1.3 Fume Extraction Hazards

- Breathing smoke, fumes, or dusts produced in applications such as welding, cutting, grinding, painting, deburring are hazardous to user's health. Proper ventilation or use of well maintained fume extraction and/or dust collection equipment helps the user avoid these hazards.
- Breathable contaminants may not be visible or have an odor.
- Stop operation and leave the area immediately if 1) breathing becomes difficult, 2) experience dizziness, impaired vision, 4) or eye/nose/mouth irritation.

1.4 Dust Collection Hazards

- Dusts from many welding, cutting, grinding, painting, or deburring applications can be combustible.
- Do not use or install equipment where any potential for combustible fumes or dusts are present, until a qualified person has indicated it is safe to do so.
- Never use or install equipment where the potential for combustible fumes or dusts are present without a fire/explosion protection system.

1.5 Safety Stickers

- This machine is equipped with safety stickers to remind operators of the inherent dangers during use and maintenance.
- The stickers are only reminders, and all safety precautions contained in this manual must be well understood and adhered to by all users.
- See **APPENDIX 3: Sample Safety Stickers** for example of stickers applied to machine.

SECTION 2 - SPECIFICATIONS

2.1 Diagram & Description

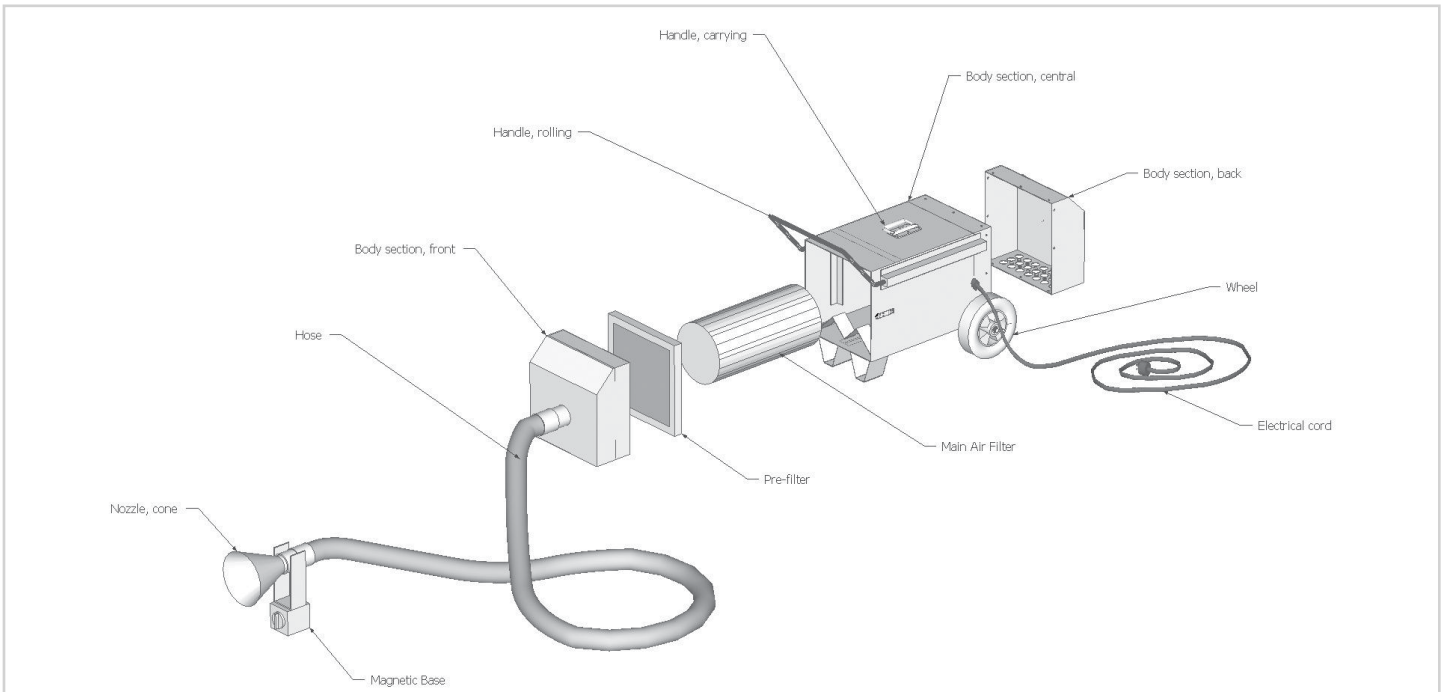

2.2 Product Specifications

| Model | Motor (H.P.) | Airflow (CFM) | Input Power | | | | Net Weighth (lbs.) | Noise @5ft (dB) |
|-------------|--------------|---------------|-------------|---------|------|--------|--------------------|-----------------|
| | | | Phase | (volts) | (hz) | (amps) | | |
| ALL FX-MVAC | 1.0HP x 2 | 105/210 | 1 | 120 | 60 | 16.0 | 48 | 68/77 |

2.3 Filter Specifications

| Unit | Filter Description | Filter Area (sq. ft.) | Filter Efficiency | Reusable |
|--------------|--------------------------|-----------------------|-------------------|----------|
| FX-MVAC-NANO | 16" Nanofiber Filter | 55 | MERV 15 | Yes |
| FX-MVAC-POLY | 16" Spunbond Poly Filter | 44 | MERV 11 | Yes |
| FX-MVAC-HEPA | 16" HEPA Filter | 40 | MERV 17 | No |

For information on inspecting and cleaning filter, or purchasing replacement filters, contact FumeExtractors at 1-866-651-9762

SECTION 3 - PRE-INSTALLATION

3.1 To Setup or Install Safely



- Do not place unit near flammables or combustible surface.
- Refer to Section 2: Specifications, to know the electrical requirements of the unit you are installing and ensure adequate input power that is properly sized, rated, and protected.
- This unit must be grounded for safe operation.

3.2 Un-Packaging

1. Immediately upon receiving the unit, carefully examine the carton for damage during transit.
2. Remove packing material.
3. Avoid tipping or inverting during handling.
4. The item serial number, model, and electrical ratings are listed on the nameplate. Record this information in the Maintenance Record provided in **APPENDIX 1: Maintenance Record**, or your own preventative maintenance system.

3.3 Selecting a Location

- Choose a location where the unit will be used, near the operator.
- Choose a location sufficiently close to a grounded power source.

3.4 Standard View: Side & Back

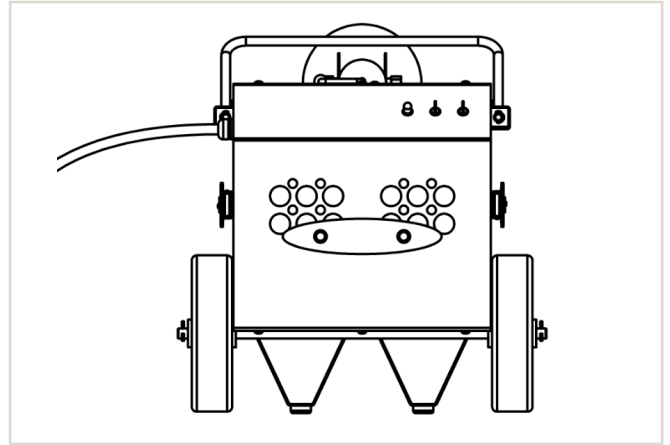
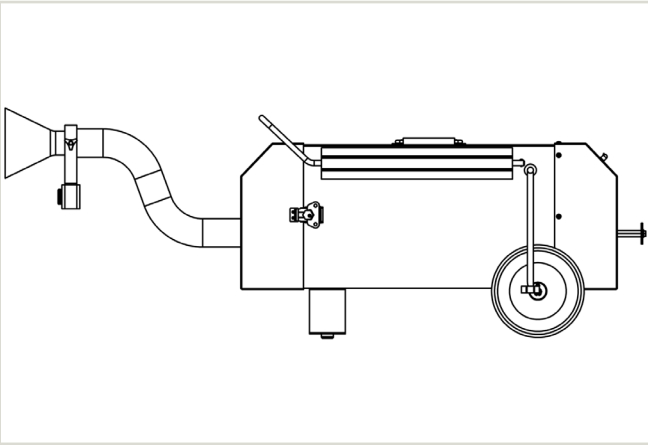

3.5 Standard View: Top & Isometric

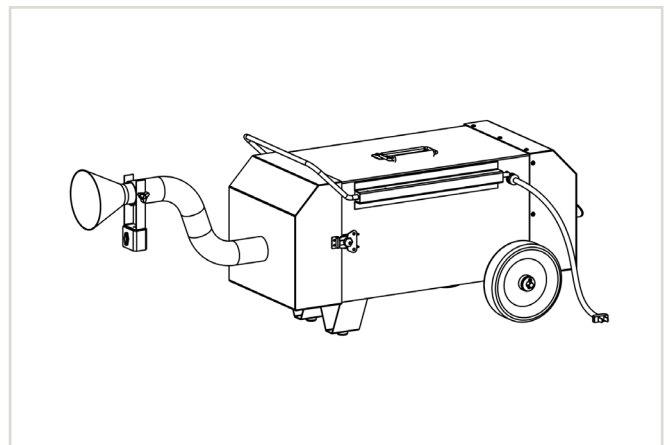
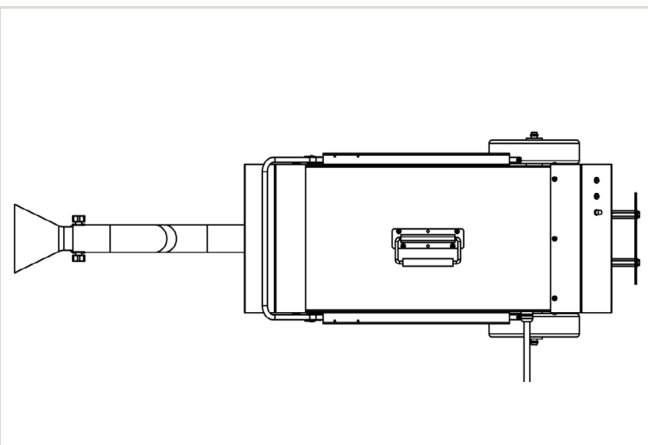

SECTION 4 - OPERATION

4.1 To Operate Safely



- Read and understand **SECTION 1: Safety Precautions** and **SECTION 4: Operation** before use
- Read and understand all Material Safety Data Sheets and Manufacturer's instructions of all process materials, consumables, and equipment used in conjunction with this equipment.
- Keep away from all mechanical moving parts including motor, gears, and other pinch points.
- Do not use product without first confirming if a Spark Arrestor is required and installed for the type of dust, or fumes you are extracting and/or collection. If you are unsure, call a FumeExtractors representative at 1-866-651-9762

4.2 Controls



- (1) Power Switch – this switch has two positions; ON and OFF.
- (2) Filter Monitoring Light – lamp lights when the helical sensor detects that filter maintenance is required.

4.3 Pre-Use Checklist

- Read and understand **SECTION 1: Safety Precautions** and ensure **SECTION 3: Pre-Installation** has been followed.
- Visually inspect the flex hoses for damage.
- Prior to use in your application, turn the unit ON, and perform a function test. To do so:
 1. Turn suction ON position.
 2. LOOK: Is the unit level, stable, and that nothing is obstructing the extraction path.
 3. LISTEN: Suction sound smooth and within expected volumes.
 4. FEEL: Place your hand on top of the unit and sense for unexpected vibration. Place your hand in front of the intake hood and sense for expected level(s) of suction.
- Inform all potential users of this equipment where they may find and review this manual.

4.4 Principles of Operation

This product is designed to capture and clean smoke and dust from light-duty welding, soldering, and grinding applications. When operating, air is drawn in to the nozzle, passes through the 2" diameter hose, then through the air cleaner's filtration system, and is finally exhausted through the bottom discharge. When the hood is placed sufficiently close to the source of dust and smoke, three stages of filtration work to clean pollution from the air. First, a pre-filter section collects the large dust particles. Second, smaller particles are trapped in the fibers of the cartridge filter with an efficiency specified in Section 2.3. Third, filtered air then passes through a carbon filter to remove any remaining odor before exhausting into the room.

This product consists of four basic components:

1. A cabinet for housing all components
2. A blower
3. Electrical assemblies
4. Collecting assemblies (filters)

4.5 Failure Event

If, for some reason, during operation there is an accident, a blockage occurs, or the suction arm begins to malfunction, the operator should immediately shut off the machine. This is considered a machine failure and the following steps should be taken:

This product consists of four basic components:

1. Turn the power switch to the OFF position.
3. Seek medical attention if an accident occurred.
4. Follow the guidelines in **SECTION 5: Maintenance & Troubleshooting**.

Remember, under no circumstance should the machine be turned back on while performing maintenance.

SECTION 5 - MAINTENANCE & TROUBLESHOOTING

5.1 To Maintain this Product Safely



- Read and understand **SECTION 1: Safety Precautions** and **SECTION 4: Operation** before maintenance.
- Do not breathe the dust collected from product while changing/cleaning filters or performing maintenance on this product.



- Disconnect power before performing any maintenance on unit, including filter inspection. The input power to this unit is high voltage, and touching any live electrical parts can cause fatal shocks or severe burns. Do not touch live electrical parts.



- Keep away from all mechanical moving parts including motor, gears, and other pinch points while operating.



- Operating this unit causes some parts to heat to a point that will burn bare hands. Before maintenance allow parts to cool, or use proper tools and personal protection equipment during maintenance.

5.2 Tools Required



EYE
PROTECTION



RESPIRATOR



GLOVES



AIR GUN

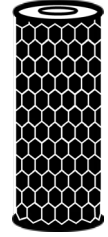

REPLACEMENT
FILTER
(if required)

5.3 Routine Maintenance Schedule

The manufacturer recommends the following routine maintenance based on light-duty use in normal operating conditions. Service more frequently if the unit is used in severe conditions.

| Frequency | Manual Reference |
|--|------------------|
| Pre-Use | |
| <ul style="list-style-type: none"> Perform pre-use checklist to ensure operating correctly. | 4.3 |
| Filter Monitoring Light is ON | |
| 1. Service Filter | 5.4 |
| Every (12) months or every X times Filter is Serviced | |
| <ol style="list-style-type: none"> Clean unreadable labels and exterior surfaces Check for tears in flex hoses and fitting of hose clamp Remove collection hose and wash with warm water mixed with mild detergent (Allow 24 hours to dry before use). Inspect cabinet for loose wiring or cracked insulation. Examine vacuum motors for signs of unusual wear. | |

5.4 Servicing Filter

The Filter Indicator Light will come on if the filters become clogged. It is actuated by a differential pressure switch contained inside the unit. The unit can continue to run with the light illuminated, however airflow will be reduced further. Operating the unit for extended periods of time with the Filter Indicator Light illuminated may cause the motor to overheat

- Review Maintenance Safety in Section 5.1
- Turn off power and disconnect input power cord.
- Detach front body by first unclasping twist-lock latches located on each side of the main body.
- Remove Filter gently so as to minimize agitating dirt and dust, and place it in a bag/container.
- Clean filter:
 - Use clean/dry air only at a pressure not more than 80PSI at 12" from media.
 - Direct the compressed air through the filter from the clean side, running the nozzle up and down the filter pleats.
 - Do not bring either nozzle in contact with the filter media as damage is likely to occur.
- Inspect filter for any damage and replace if necessary.
- Clean cabinet interior of dirt and debris.
- Reassemble by first installed the clean filter; then reattach the front body and re-engage the twist-lock latches on each side of the main body.
- Turn ON unit and check Filter Indicator Light. If lamp is illuminated, repeat all steps above.

5.5 Troubleshooting Procedure

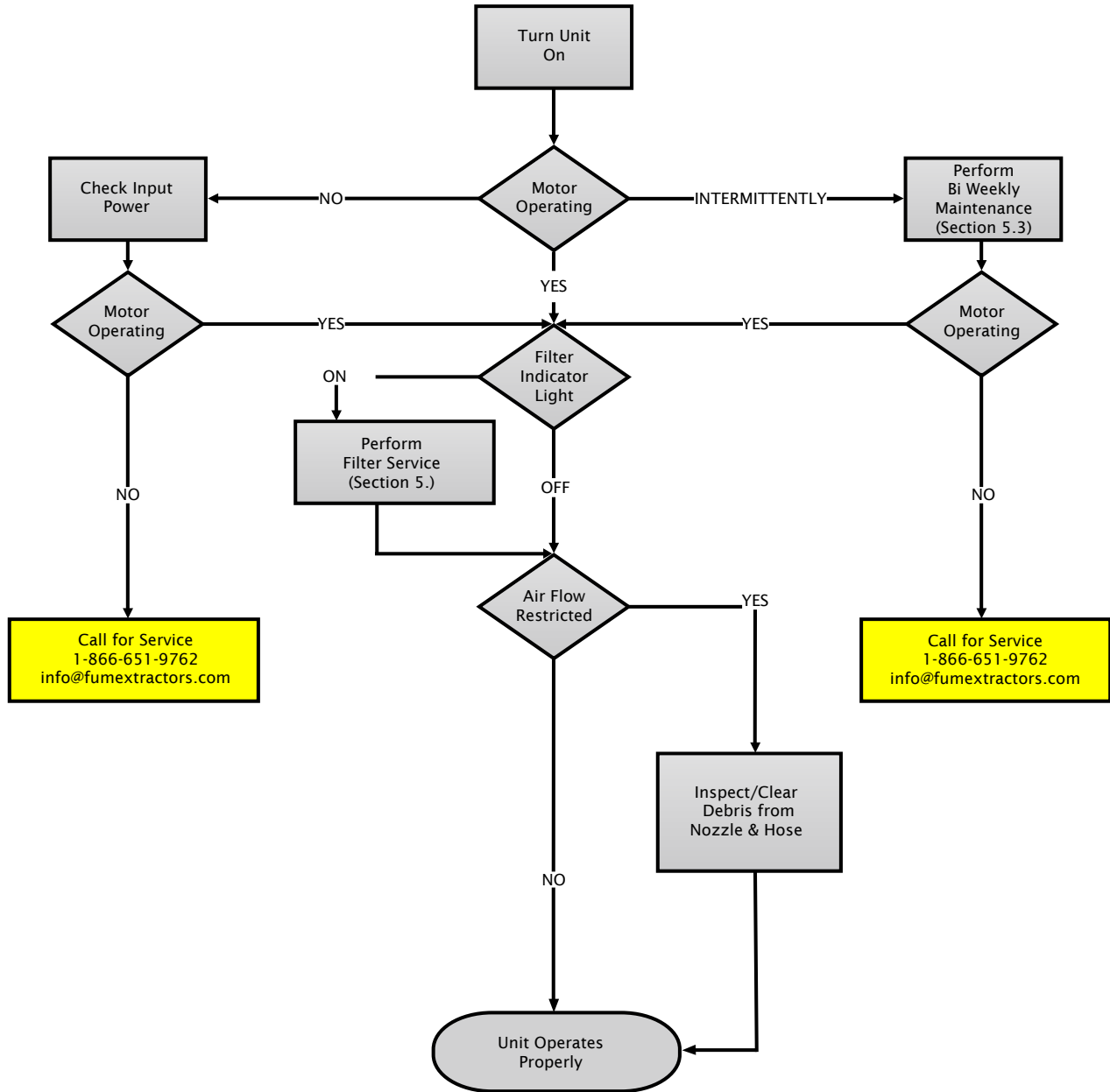

APPENDIX 1 - ELECTRICAL DIAGRAM MANUAL

[120v] Single-Phase Power



**ELECTRIC
SHOCK
HAZARD**

Disconnect power before performing any maintenance on unit, including filter inspection. The input power to this unit is high voltage, and touching any live electrical parts can cause fatal shocks or severe burns. Do not touch live electrical parts.

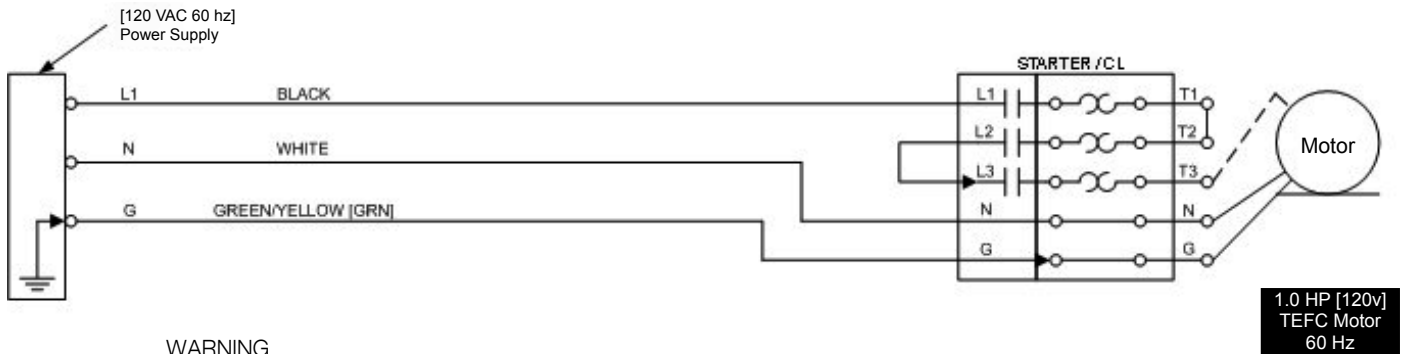

WARNING

Do not route auxiliary contact cable in the same conduit as motor cable

NOTE

Specific transformer wiring may differ depending on voltage configuration.

Units in brackets [] refer to imperial system values

APPENDIX 2 - MAINTENANCE RECORD

Use this page to record filter changes, replacement parts, and other maintenance.

| Date | Description of Service | Serviced By | Location | Comments |
|------|------------------------|-------------|----------|----------|
| | | | | |
| | | | | |
| | | | | |
| | | | | |
| | | | | |
| | | | | |
| | | | | |
| | | | | |
| | | | | |
| | | | | |
| | | | | |
| | | | | |
| | | | | |
| | | | | |
| | | | | |

APPENDIX 3 - REPLACEMENT PARTS

FX-MVAC Series

| DESCRIPTION |
|--|
| 16" Nanotech XV Cartridge Filter, 55 sqft, MERV 15 |
| 16" Polytech XI Cartridge Filter, 44 sqft, MERV 11 |
| 16" HEPA Cartridge Filter, 40 sqft, MERV 17 |
| Activated Carbon Panel Filter |
| 2" to 6" Diameter Suction Nozzle |
| Magnetic base with Bracket |
| 1.5" to 2" Diameter Mig-gun Adaptor |
| Metal Mesh Prefilter |
| 1.7HP Motor |
| 2" Diameter Flexhose Cuff |
| 2" Diameter Flexhose (per foot) |
| 2" Diameter x 10ft, Flexhose |
| 2 Union to join (2x) 2" Diameter Flexhoses |
| LED Clean Filter Indicator Light |
| Hi/Low/Off Toggle Switch, 20A 125V |
| Set of Motor Brushes |

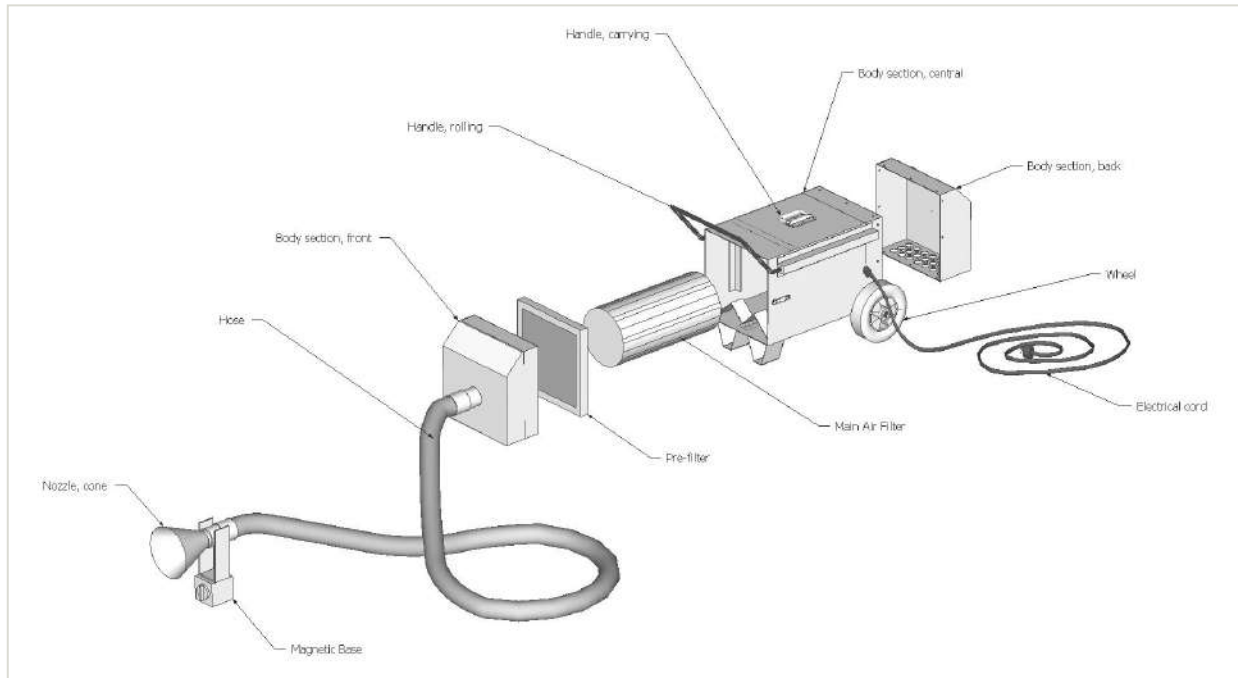





APPENDIX 4 - SAMPLE SAFETY STICKERS

The machine is marked with a wet filtration safety sticker to remind the operator of safe working practices:

| WARNING | AVERTISSEMENT | ADVERTENCIA | WET FILTRATION |
|---|--|---|----------------|
| DO NOT USE this equipment: | NE PAS UTILISER cet équipement : | NO USAR este equipo: | |
|  <ul style="list-style-type: none"> To collect smoke, fumes, liquid vapors, or aggressive fumes such as acids | <ul style="list-style-type: none"> Pour l'extraction de fumées ou d'émanations de plus de 82 °C / 180 °F. | <ul style="list-style-type: none"> Para extraer humo o gases superiores a 180°F / 82°C. | |
|  <ul style="list-style-type: none"> If the power cord has been damaged or ground (third prong) removed. | <ul style="list-style-type: none"> Si le cordon d'alimentation est endommagé ou si la mise à la terre (troisième broche) a été retirée. | <ul style="list-style-type: none"> Si el cable está dañado o se le ha quitado el tierra (tercera punta). | |
|  <ul style="list-style-type: none"> Without the proper water level in basin | <ul style="list-style-type: none"> Si le niveau d'eau dans le bassin n'est pas adéquat. | <ul style="list-style-type: none"> Sin el nivel de agua adecuado en el depósito. | |

The machine is marked with safety stickers in appropriate places to remind the operator of safe working practices.

| STICKERS APPLIED TO MACHINE | | | | |
|--|---|---|---|---|
| Figure 1 | Figure 2 | Figure 3 | Figure 4 | Figure 5 |
| Foot Trap Hazard | Falling Objects Hazard | Moving Parts Hazard | Electric Shock Hazard | Loud Noise Hazard |
|  CAUTION FOOT TRAP HAZARD PROPER FOOTWEAR REQUIRED |  CAUTION FALLING OBJECTS HAZARD DO NOT PLACE OBJECTS ON MACHINE |  CAUTION MOVING PARTS HAZARD DO NOT TOUCH - DISCONNECT POWER BEFORE OPENING |  CAUTION ELECTRIC SHOCK HAZARD SERVICE BY TRAINED PERSONNEL ONLY |  CAUTION LOUD NOISE HAZARD WEAR EAR PROTECTION DURING OPERATION |

NOTES

NOTES

LIMITED EQUIPMENT WARRANTY

For a period of 2 years from the date of purchase, FumeXtractors products are warranted to be free from defects in material, workmanship, and construction, when used in accordance with installation, maintenance instructions, and expressly stated proper use application(s). FumeXtractors will repair or replace, at our option, any defective parts which fail during the warranty period. This warranty is limited to replacement parts ONLY, and does not cover personal liability, property loss, normal wear; and does not cover losses resulting from (or due to) improper installation, inadequate maintenance, misapplication, misuse, or use above rated capacities.



Visit our Website for more
information on this product
www.fumextractors.com

11088 Gravois Industrial Ct.
Saint Louis, MO 63128
info@fumextractors.com